

超精密卡盤生爪

SOFT JAWS FOR SUPER PRECISION CHUCK

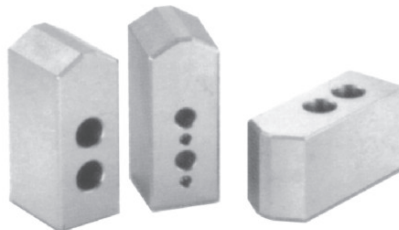
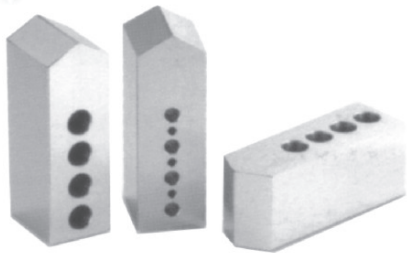

J-04

J-06

J-08

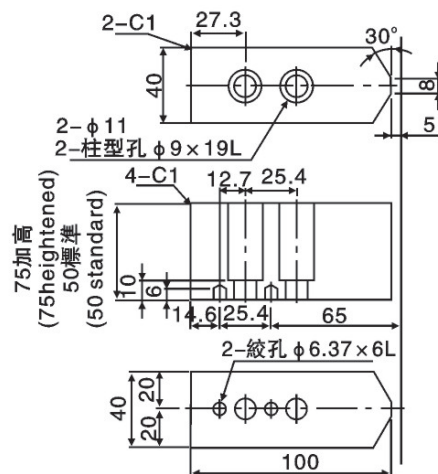
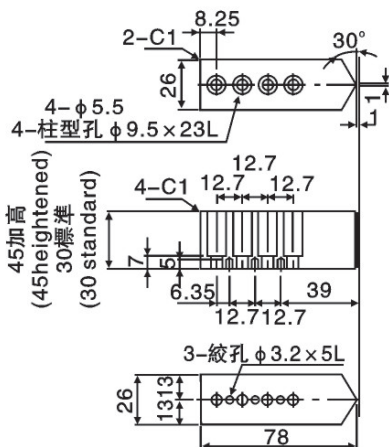
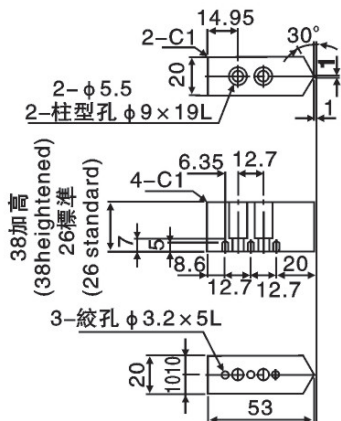

T-NUTST型塊

SUITABLE FOR POWER CHUCKS

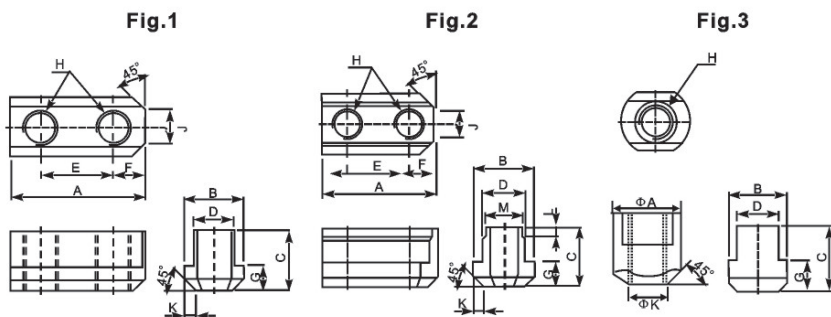

尺寸表 / Size table

型式 Model	A	B	C	D	E	F	G	H	J	K	L	M	Fig	
中空 Thru	T-5"	26	14.5	15	10	14	6	5.5	M8	5	2		1	
	T-6"	36	17.5	18.5	12	20	8.2	7.5	M10	8	2.5		1	
	T-8"	46.5	20.5	20.5	14	25	10.5	8.5	M12	12	4		1	
	T-10"	51	22.5	21.5	16	30	11	8.5	M12	11	3		1	
	T-12"	55.5	29.5	27.5	21	30	12	11.5	M16	13	4.5		1	
	T-15"(18")	80	33.5	45.5	24	43	17	16.5	M20	11	5	8	22	2
中實 Non-Thru	NT-6"	36.5	17.5	22.5	12	20	7.5	7.5	M10	6	3		1	
	NT-8"	48	20.5	25.5	14	25	11	9.5	M12	8	4		1	
	NT-10"	55	22.5	25.5	16	30	11	9.5	M12	8	4		1	
	NT-12"	55.5	26.5	33.54	18	30	11.5	13.5	M14	12	5		1	
	NT-15"(18")	42	35	39.5	25.5			19	M20		25			3
	NT-15"(18")3.0	42	35	41.5	26			19	M20		25			3
	NT-21"(24")	46	37.5	45	25			19	M20		26.5			3

注：非標可定做 Customized spec can be made.